



BioEntry W

Compact Outdoor Fingerprint Reader/Controller

Installation Guide

EN 101.00.BEW V1.30

Important Safety Information

Carefully review the information within the user manual before installing/operating the device. Pay careful attention to the warning and cautions below as they are here to prevent any risk/damage to any person(s) or property associated with the device.



Warning

Failure to heed these warnings may lead to serious injury or even death!

Installation

- Do not install the device near heat sources such as radiators, heat registers, and stoves.
- Do not install the device near areas of large electromagnetic interference.

Usage

- Do not disassemble, repair or reconstruct the device. Contact your nearest Suprema dealer for technical support.
- Only use the device its intended use.



Caution

Failure to heed these cautions may lead to minor injury or damage the device.

Installation

- Do not install the device in a place subject to direct sun light, humidity, dust or soot.
- Do not leave cables (especially power cables) exposed to the outer environment.
- Do not install the device near objects with a strong magnetic field such as magnets, computer monitors (especially CRT), TV screens and speakers.
- Secure I/O, the electrical locking device and access controller must use independent power source.

Usage

- Do not drop or apply any physical shock/impact to the device.
- Regularly clean the product with a soft dry cloth; avoid benzene or alcohol.

Contents

About Fingerprint Recognition	4
How to Enroll a Fingerprint on the Device	5
Components	7
Product Description	9
Dimensions	11
Cable Specifications	12
Installation	13
System Configurations	14
Connections	17
Resetting Network Settings	28
Electrical Specifications	29
Product Specifications	30
Troubleshooting	31
Precautions for Device cleaning	32
FCC Rules	33

About Fingerprint Recognition

What is a fingerprint?

Fingerprints are individual's own biometric information and do not change throughout one's life. Fingerprint recognition is a technology that verifies or identifies an individual using such fingerprint information. Free from the risk of theft or loss, fingerprint recognition technology is being widely used in security systems replacing PIN or cards.

What is fingerprint recognition?

Fingerprints consist of ridges and valleys. Ridge is a flow of protruding skin in a fingerprint while valley is the hollow between two ridges. Each individual has unique patterns of ridges and valleys; fingerprint recognition makes use of these differences to differentiate between individuals.

Fingerprint sensors generate 2-dimensional fingerprint images using various technologies: optical, capacitive, or thermal. Fingerprint template is a collection of numeric data representing the features of a fingerprint. Fingerprint templates are saved inside the memory of BioEntry W, and used for identification.

Suprema's Personal Information Protection Technology

To avoid privacy concern, Suprema's fingerprint products do not save fingerprint images itself. It is impossible to reconstruct a fingerprint image from a fingerprint template which is just numeric data of the features of a fingerprint.

How to Enroll a Fingerprint on the Device

Suprema's fingerprint products have outstanding recognition performance regardless of the user's fingerprint condition or positioning. However pay careful attention to the following instructions to maximize the performance of the device.

Fingerprint Enrollment

- It is recommended to enroll the index or middle finger.
The thumb, ring or little finger are generally more difficult to position properly.

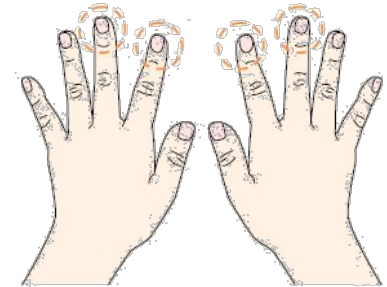

How to place a finger on a sensor

- Fully cover or provide maximum contact to the surface of the sensor with the desired finger. People tend to place the tip of a finger on the sensor; this will only provide a small area of the finger to be captured and will result in poor performance.
- Place the core of the fingerprint near the center of the sensor. This will ensure a good template will be created. The core of a fingerprint is a center where the spiral of ridges is most dense.

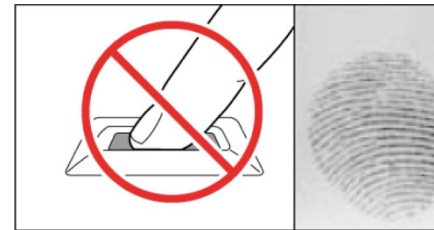
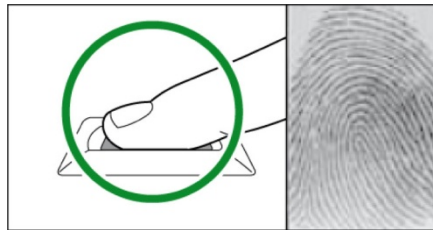

How to Enroll a Fingerprint on the Device

Fingerprint Enrollment Precautions

Operational Warnings

- If a finger is wet or too moist, wipe off the moisture then try the scan again.
- If a finger is covered with dust or impurities, clean the finger then try the scan again.
- If a finger is dry, breathe warm air onto the finger then try the scan again.

Solving Authentication Difficulties

- Delete then Re-enroll the finger.
- Enroll the same finger multiple times.
- Try a different finger with a more vivid fingerprint.
- Enroll various fingers for each user.

Components

- Basic Components



BioEntry W



Diode (1)



Wall Mount Screws (2)

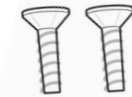

Main Unit Mounting Screws (2)



Wall Mounting bracket (1)

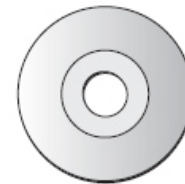

Software CD (1)

Components

- Optional Accessories



Secure I/O

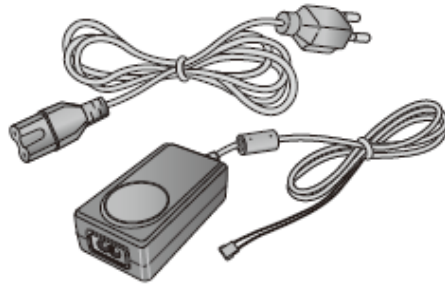

12VDC Power Adaptor



Plastic Stand



USB Fingerprint Scanner

Product Description

■ Front



LED

- Displays the current status with various colors.

RFID Scanner

- Place an RFID card over the scanner.

Fingerprint Sensor

- Place a finger on the surface of the sensor.

LED	Device Status
Green	Successful Authentication
Red	Failed Authentication
Pink	Processing
Flicker Blue/Sky-Blue Color per 2sec	Standard Operation
Flicker Red/Pink Color per 2sec	Device Locked
Flicker Blue/Red Color per 2sec	Discharged Internal Battery
Flicker Blue/Yellow Color per 2sec	Unable to Acquire an IP Address from the DHCP Server.
Flicker Red Color per 2sec	Unit Malfunction. Contact Your Suprema Dealer/Distributor.
Flicker Yellow Color per 2sec	Waiting for an Input
Flicker Yellow Color per 1sec	Requesting IP Address from the DHCP Server.

Product Description

■ Rear and Bottom

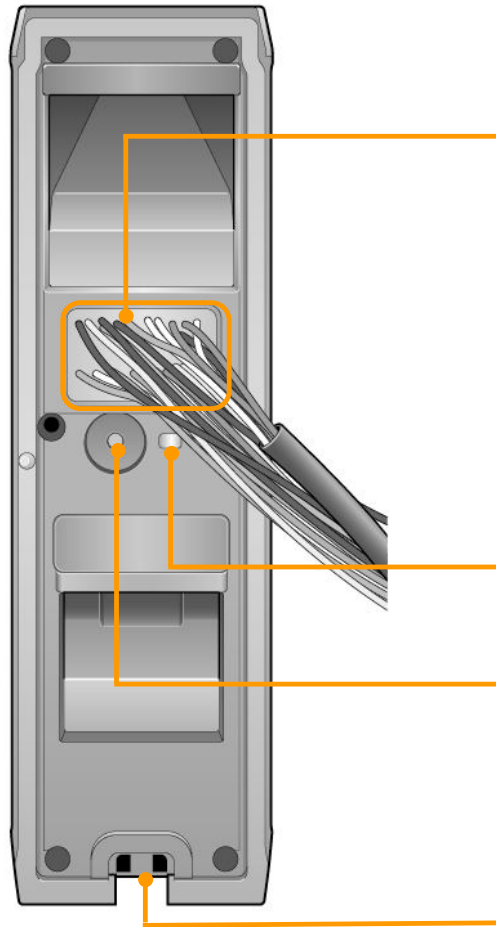

Cables

- Wiegand Input/Output Cables
- Power Cables
- RS485 Cables
- Ethernet Connector
- Input Cables
- Relay Cables

LED

- Network Status LED

Network Reset Switch

- See "Resetting Network Settings (page 28)" for more details.

Star-shaped screw hole for fixing a body to a metal bracket

Dimensions

■ BioEntry W

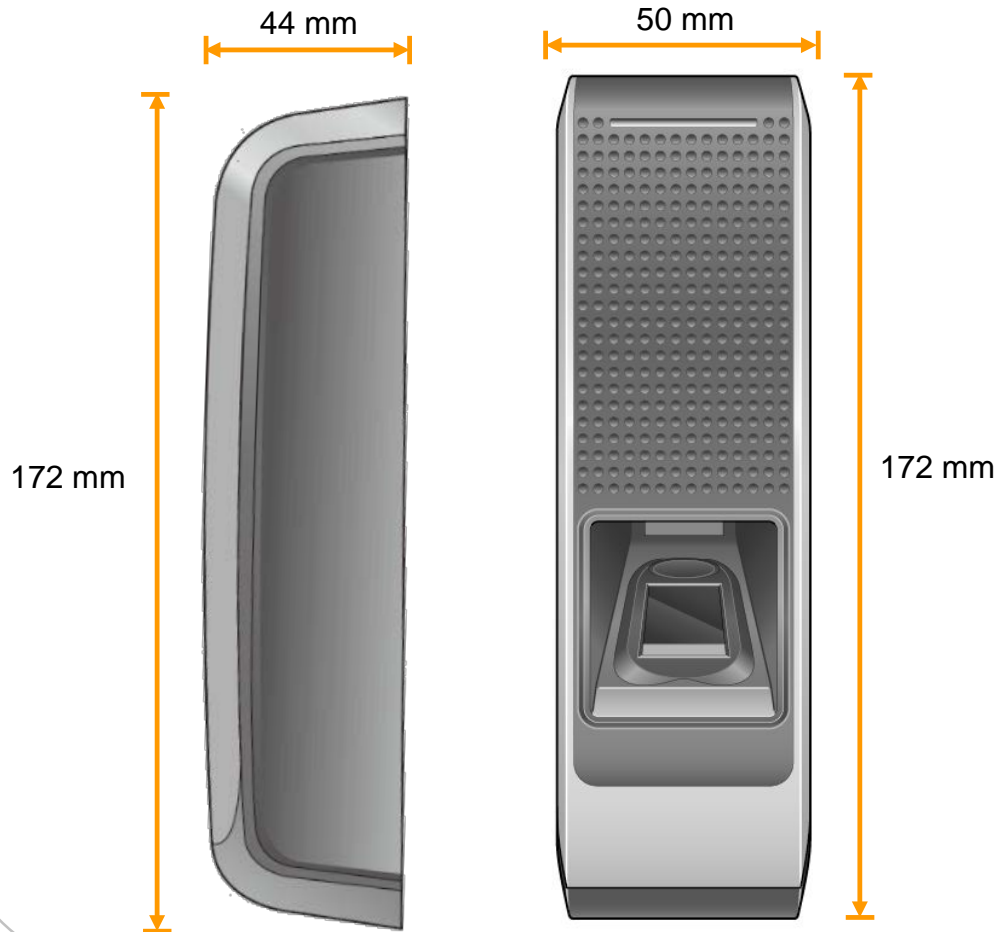

■ Wall Mounting Bracket

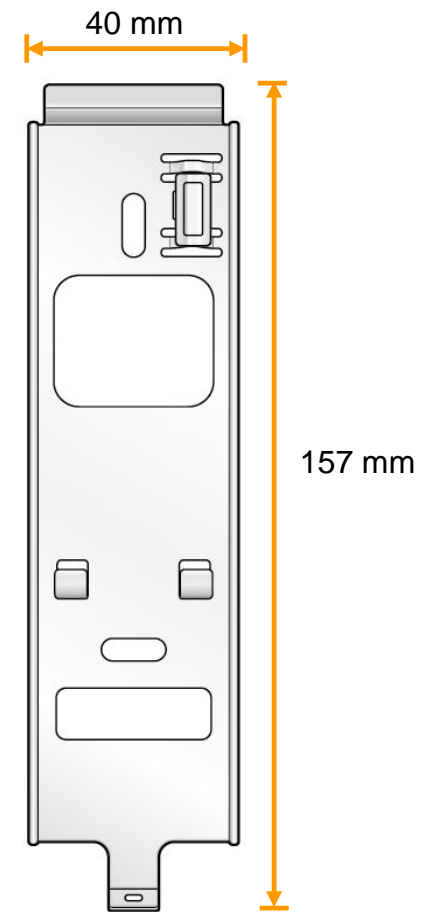

Cable Specifications

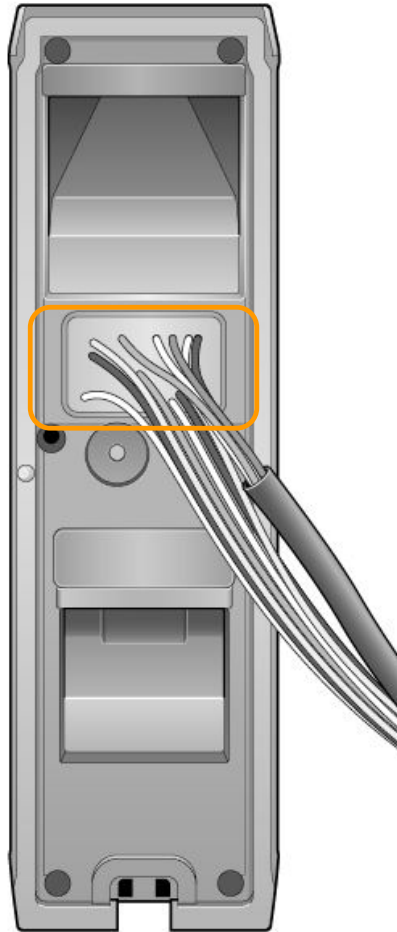

PIN	Description	Color
1	SWIN1	BROWN
2	SWIN0	PURPLE
3	ETH TXP	WHITE
4	ETH TXN	ORANGE
5	ETH RXP	BLACK
6	ETH RXN	YELLOW
7	POWER IN	RED
8	POWER GND	BLACK
9	PoE VB2	BLUE
	PoE VB2	BROWN
10	PoE VB1	RED
	PoE VB1	GREEN
11	485 TRXN	YELLOW/WHITE STRIPE
12	485 TRXP	BLUE/WHITE STRIPE
13	485 GND	BLACK/WHITE STRIPE
14	WIEGAND GND	WHITE/BLACK STRIPE
15	WIEGAND D1	WHITE
16	WIEGAND D0	GREEN
17	NC	PINK
18	RELAY NC	ORANGE/WHITE STRIPE
19	RELAY COM	GREEN/WHITE STRIPE
20	RELAY NO	GRAY/WHITE STRIPE

Installation

1. Fix the wall mounting bracket on a wall by using wall mounting screws.
2. Hook the device on the wall mount bracket.

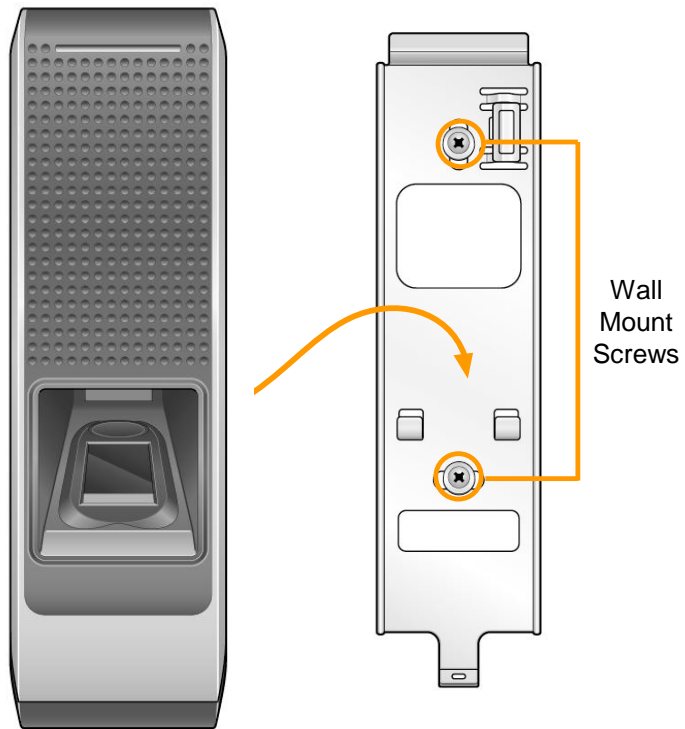

3. Fix the device to the wall mounting bracket using the star-shaped screws.

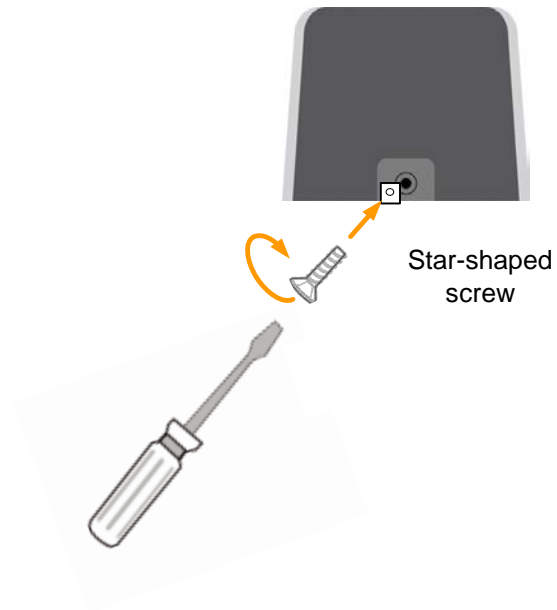

System Configurations

- Standard

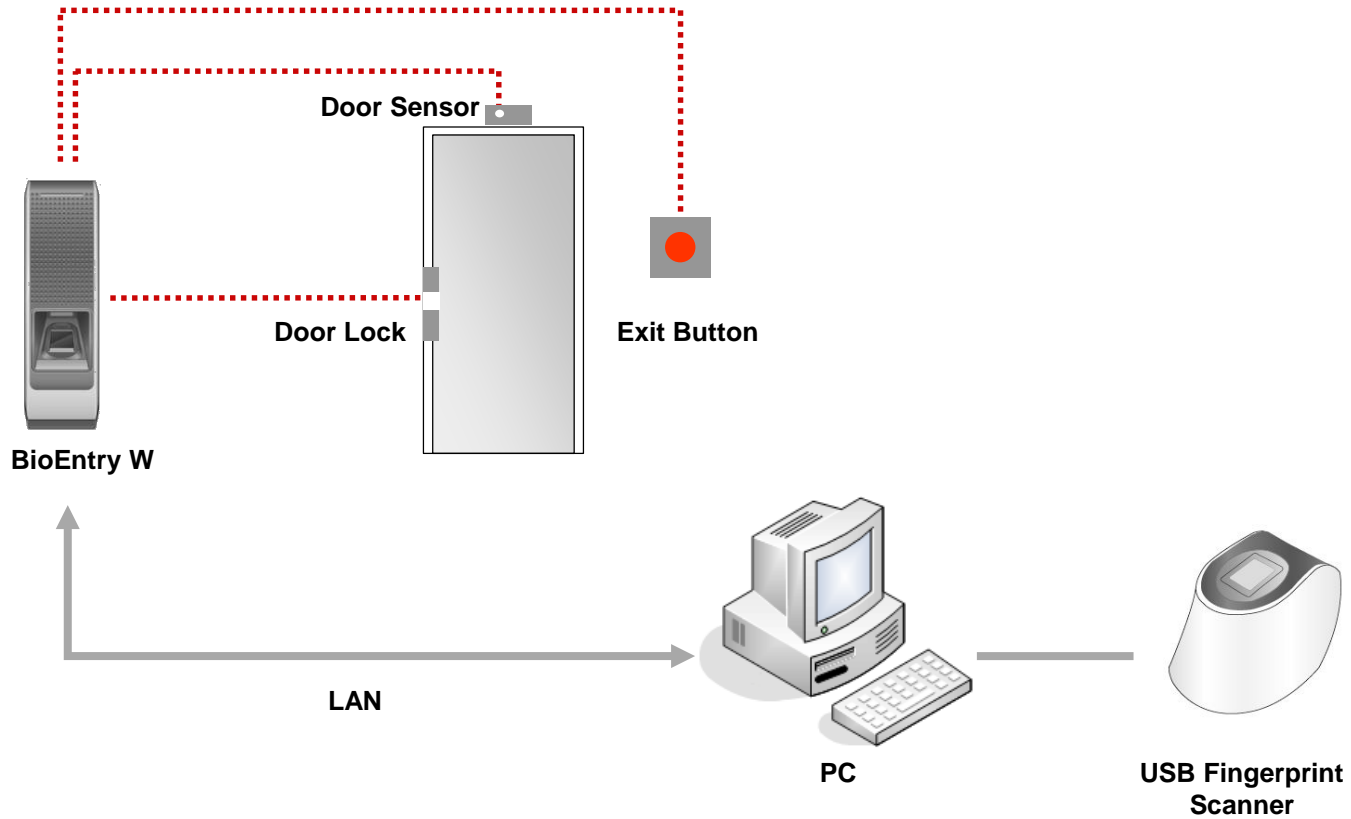

System Configurations

- Secure (Secure I/O)

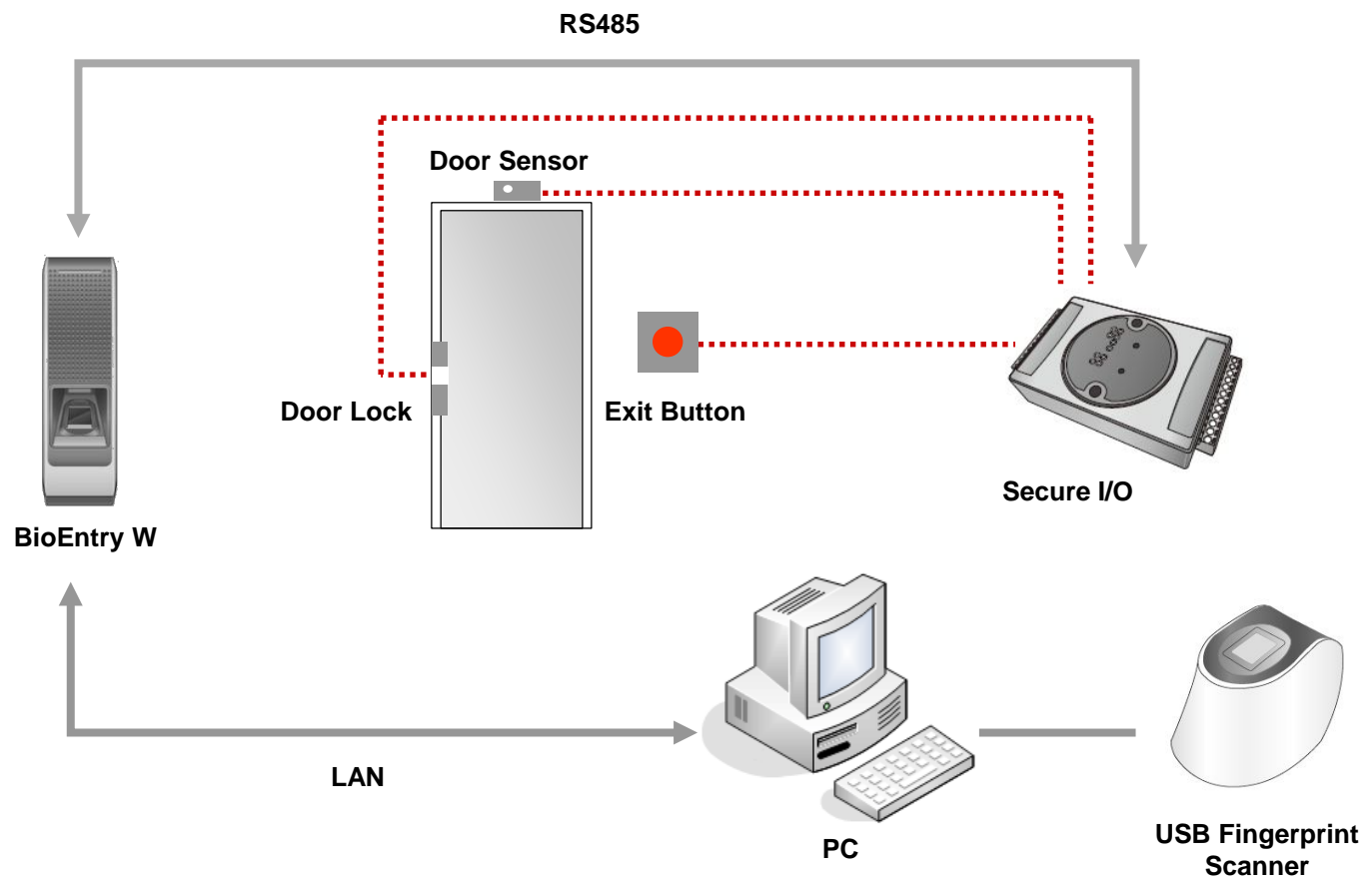

System Configurations

■ Network

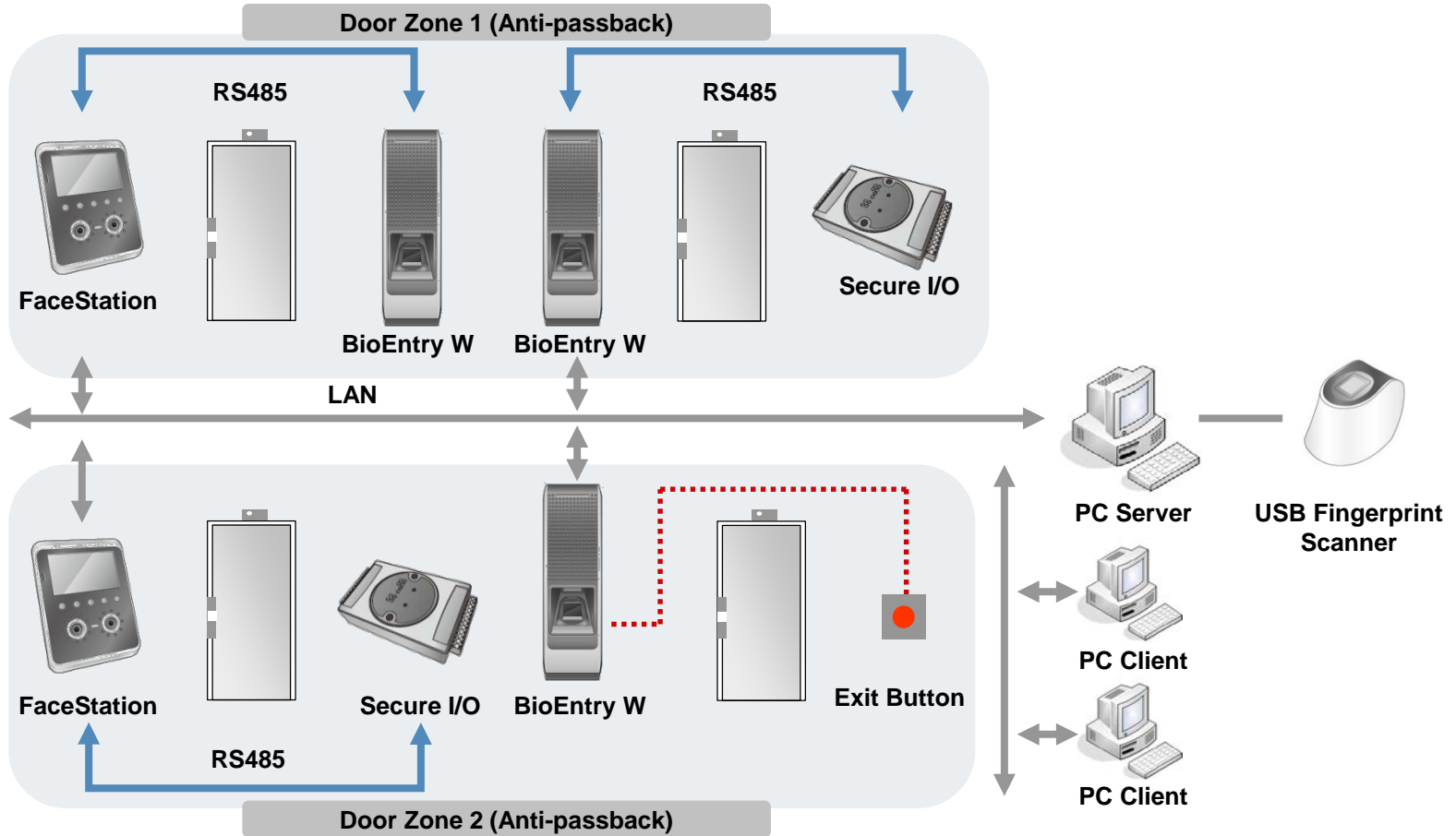

Connections

■ Power Connection

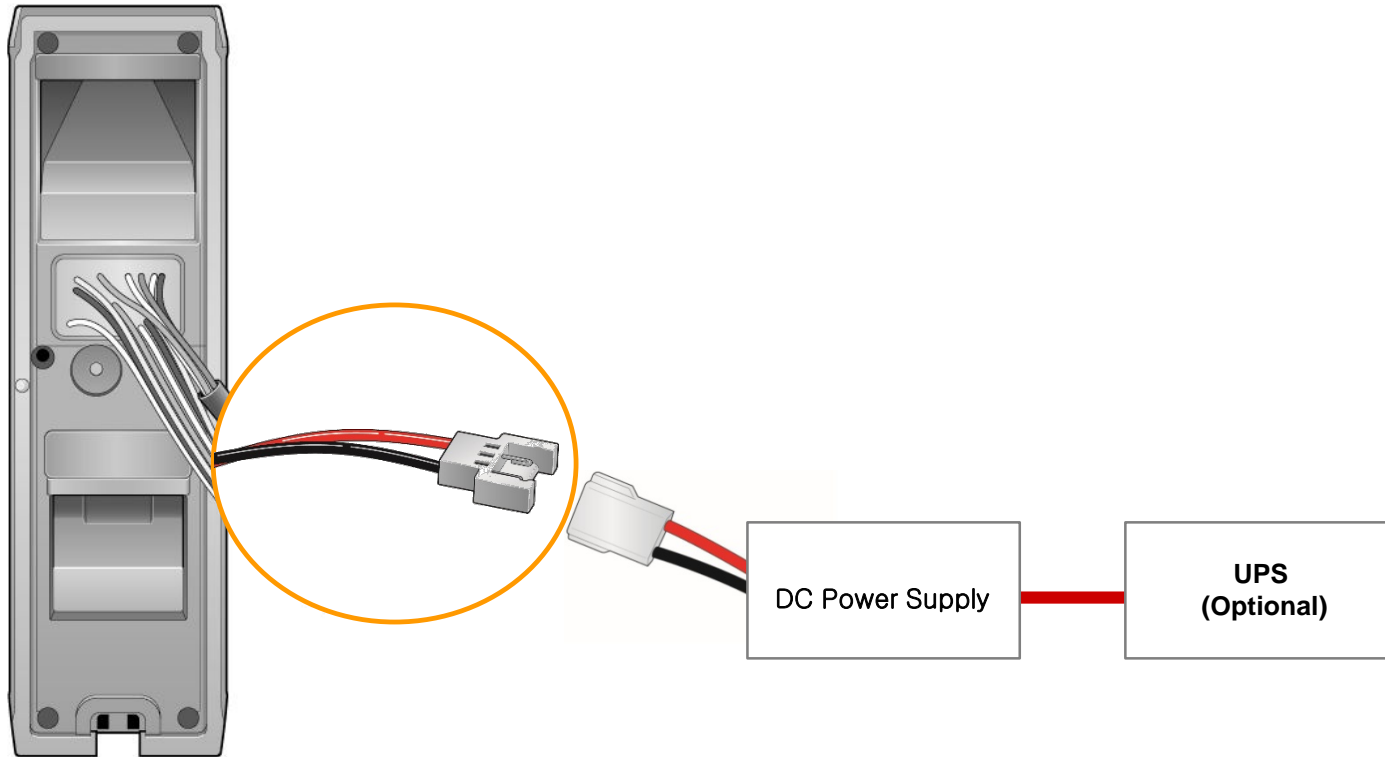

☰ Recommended Power Specifications

- 12V \pm 10%, at least 1500mA.
- Comply with standard IEC/EN 60950-1.
- Secure I/O, the electrical locking device and access controller must use independent power source.

Connections

- **Ethernet Connection (Connection with HUB)**

The device can be connected with a regular hub or PoE hub by connecting the Ethernet cable to the Ethernet terminal. PoE(Power over Ethernet) is an Ethernet connection of which the power is supplied from PSE(Power Sourcing Equipment) satisfying the IEEE802.3af standard.

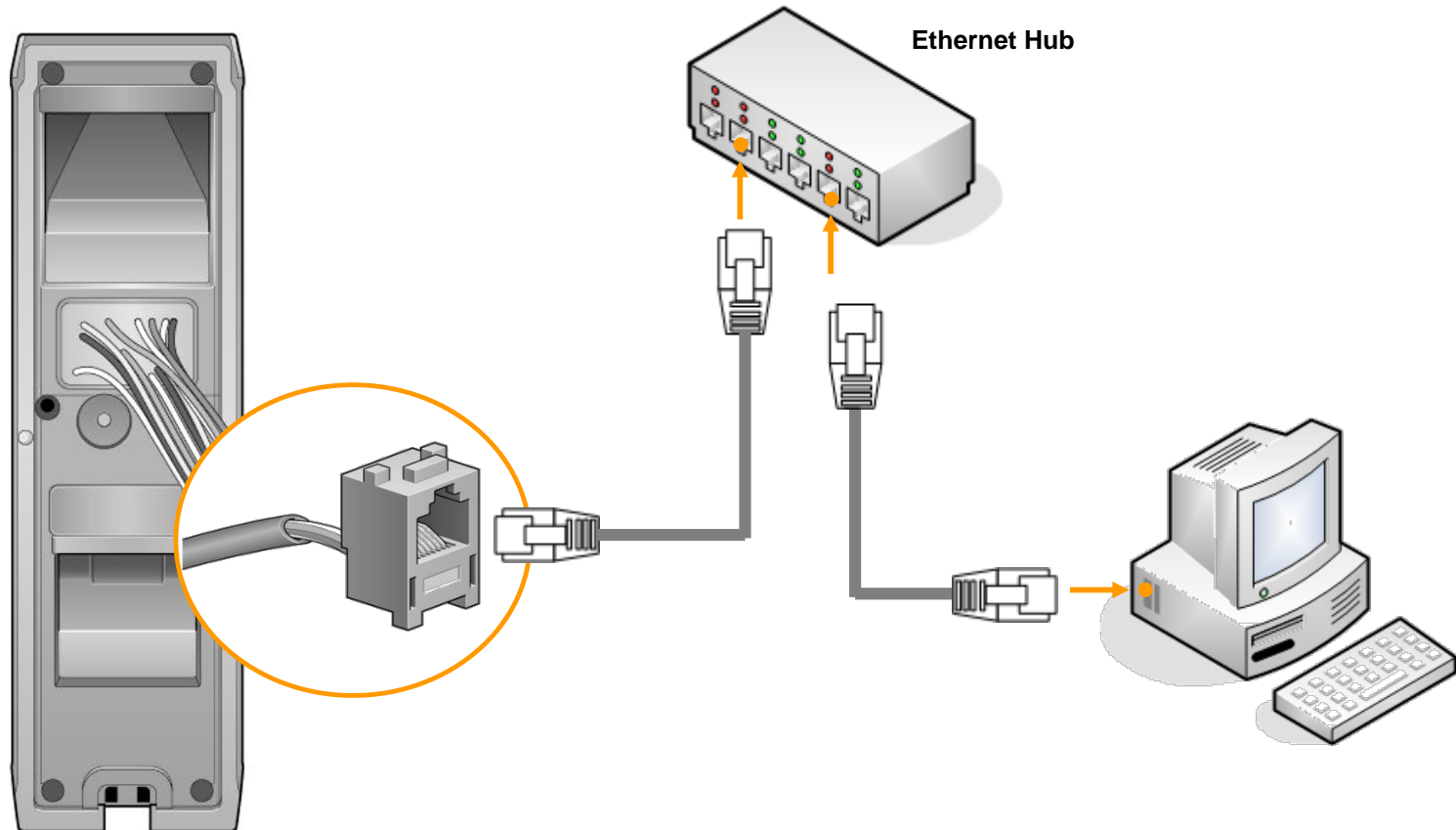

Connections

- **Ethernet Connection (Direct connection with PC)**

Use a standard CAT-5 cable to connect the device directly to a PC.
BioEntry W supports auto MDI/MDIX, therefore a crossover cable is not necessary.

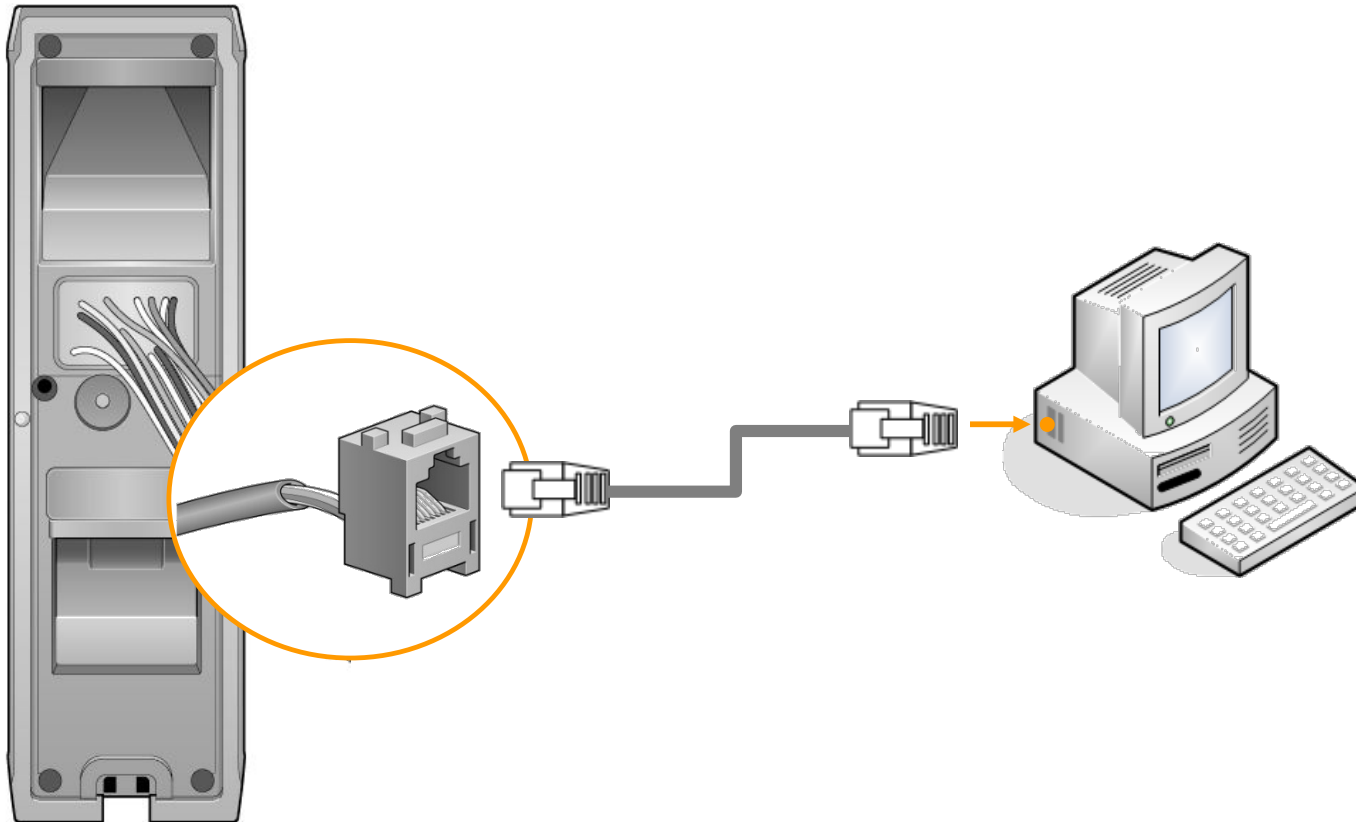

Connections

■ RS485 Connection for Host Communication

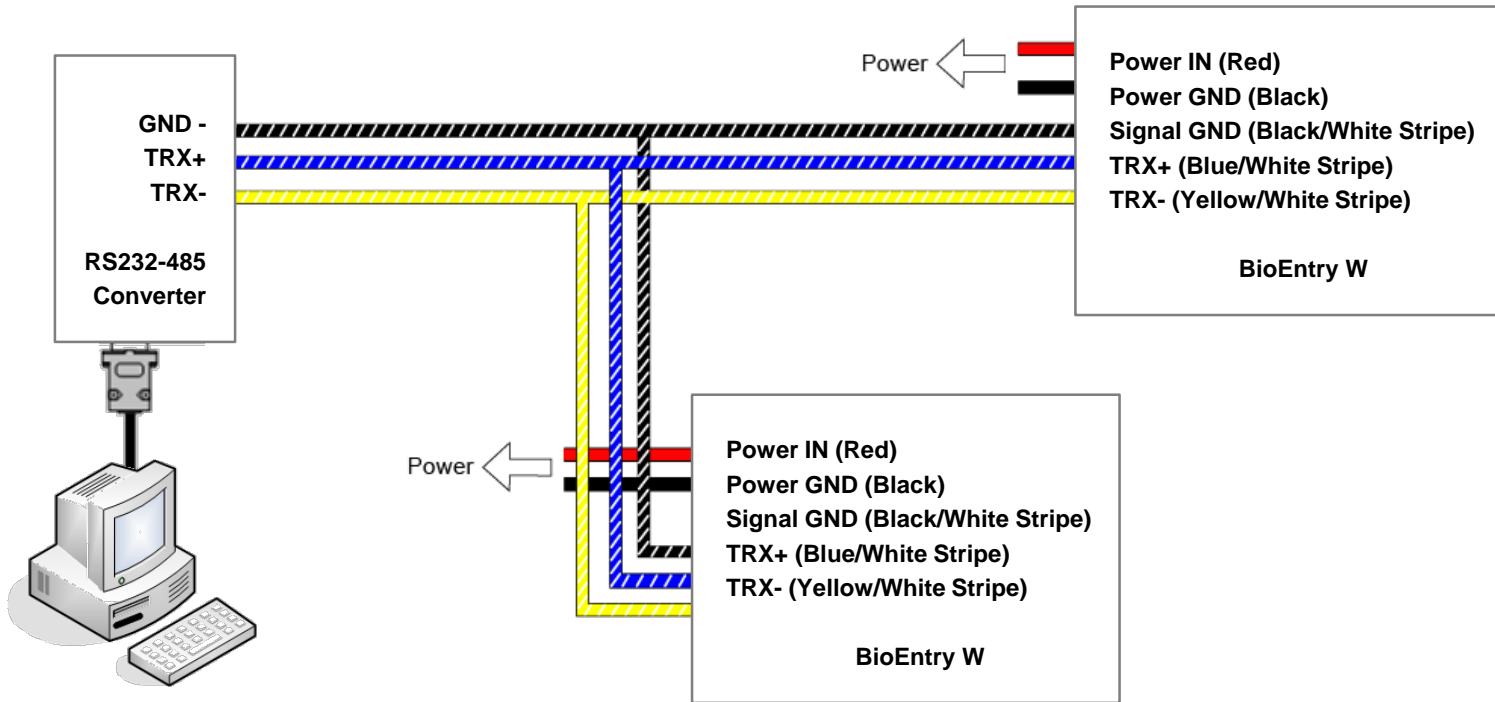

☰ Notes

- Only the devices at the both ends of the bus should be terminated. To enable termination on the RS232-485 converter, refer to the converter's manual.
- Adjust the communication speed as needed. The signal quality vary depending on wiring conditions, and it may be necessary to lower the baudrates.
- The GND signal may be omitted if and only if the GND potential difference is less than $\pm 5V$.

Connections

■ RS485 Connection for Secure I/O

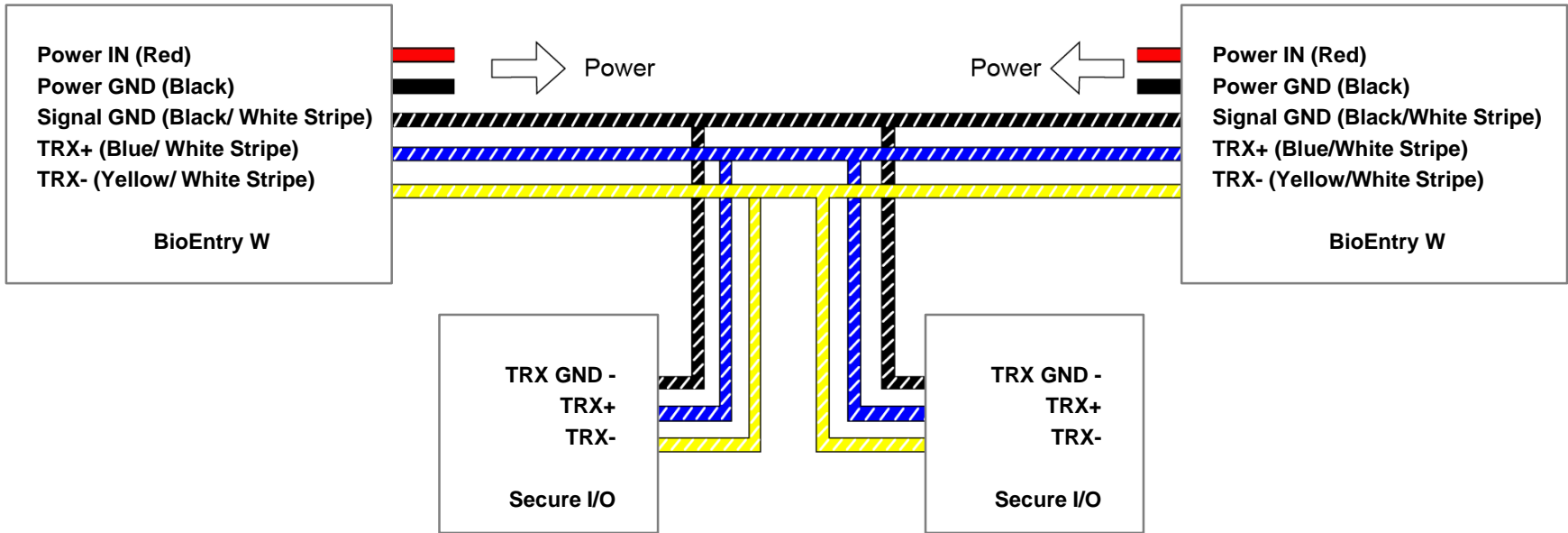

☰ Notes

- For bus termination, only the devices at both ends of the bus should be terminated.
- Maximum numbers of devices in an RS485 loop are two(2) Suprema devices and four Secure I/Os.

Connections

Relay Connection – Fail safe lock

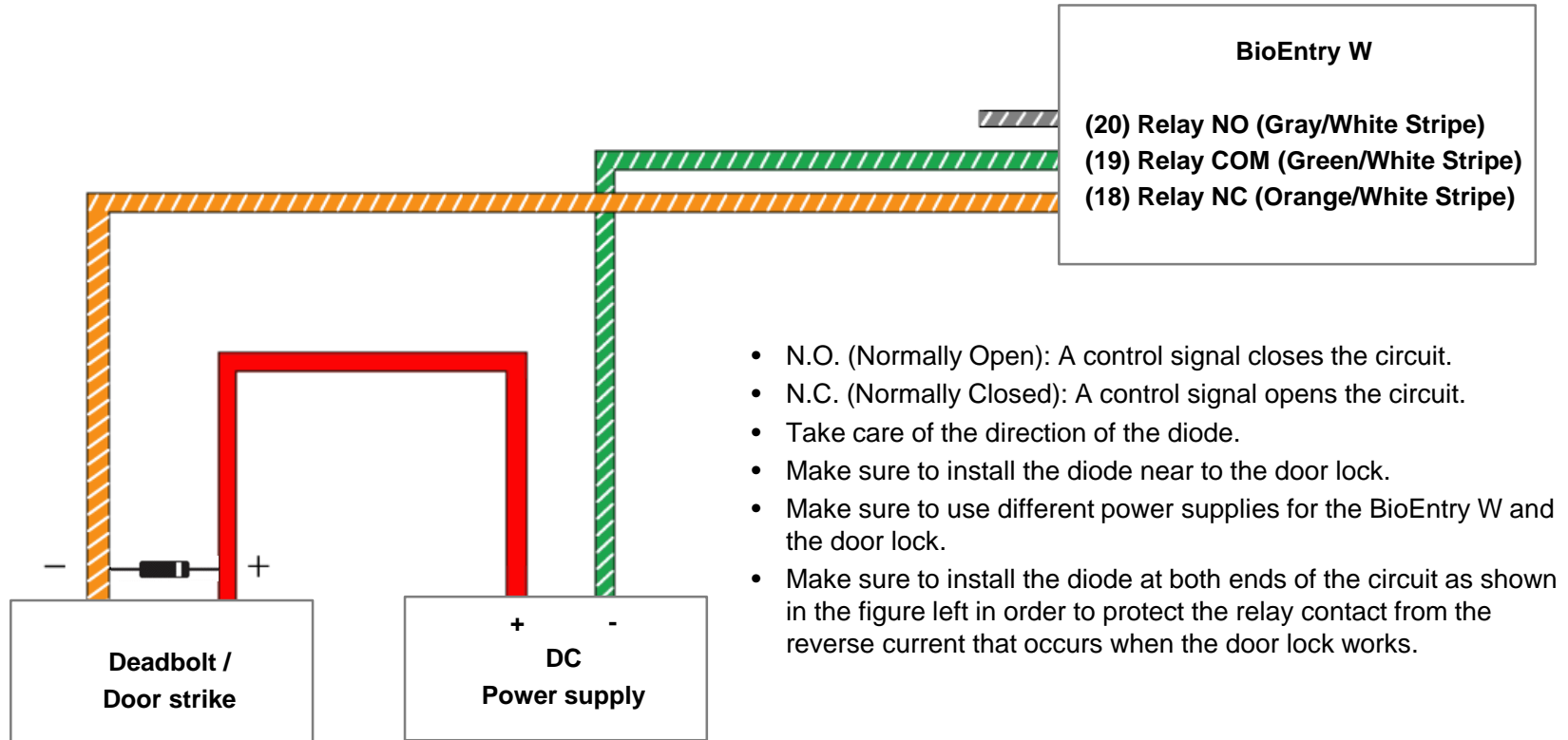

Connections

Relay Connection – Fail secure lock

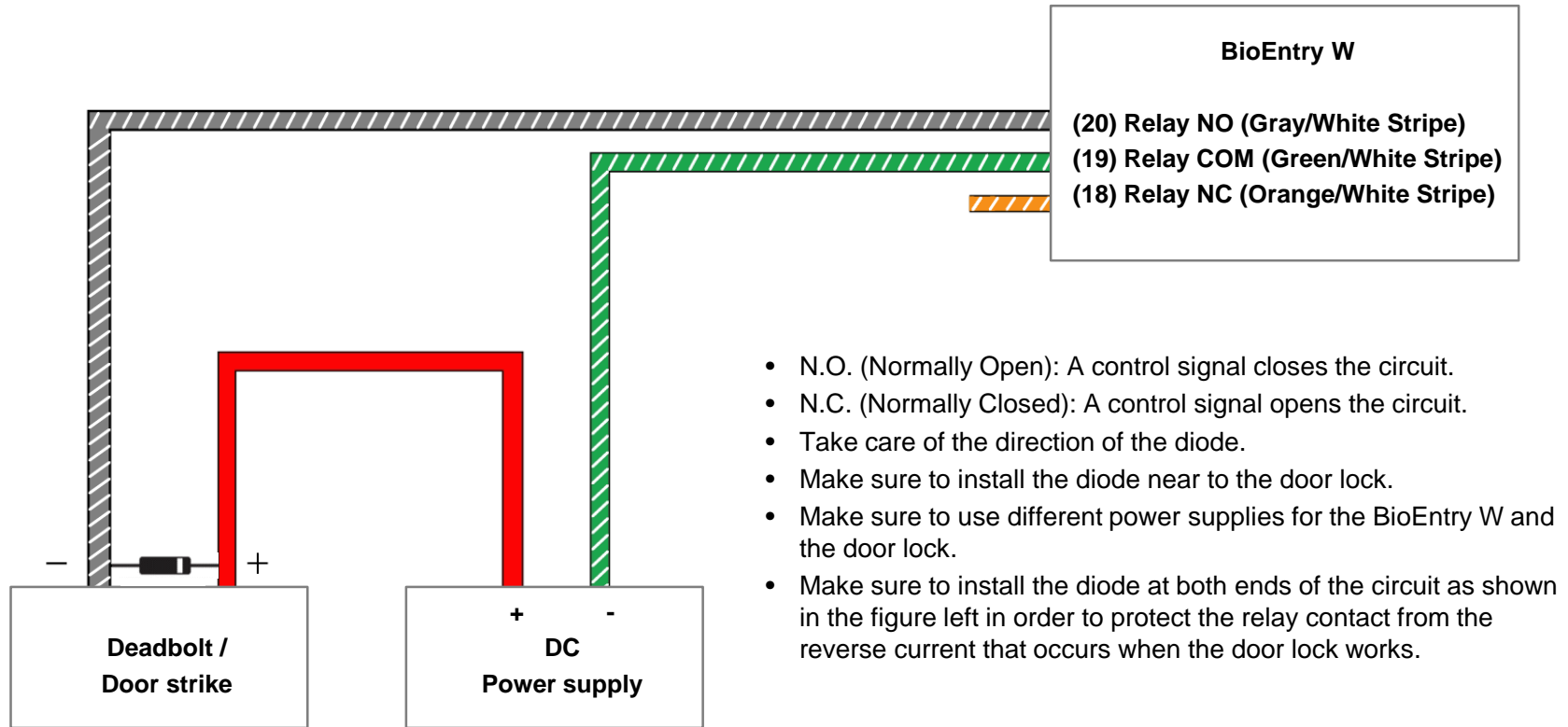

Connections

- Relay Connection - Automatic door

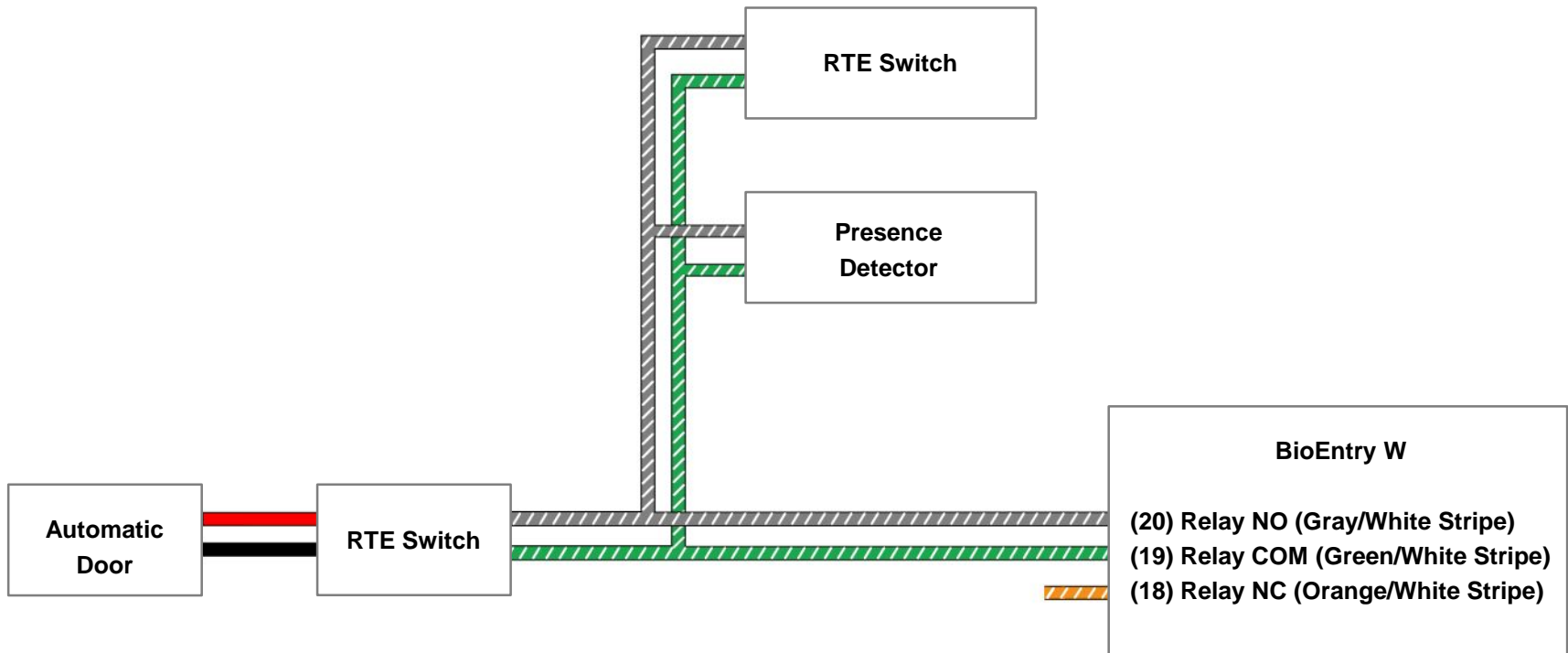

Connections

- Digital Input Connection (RTE/ Door sensor)

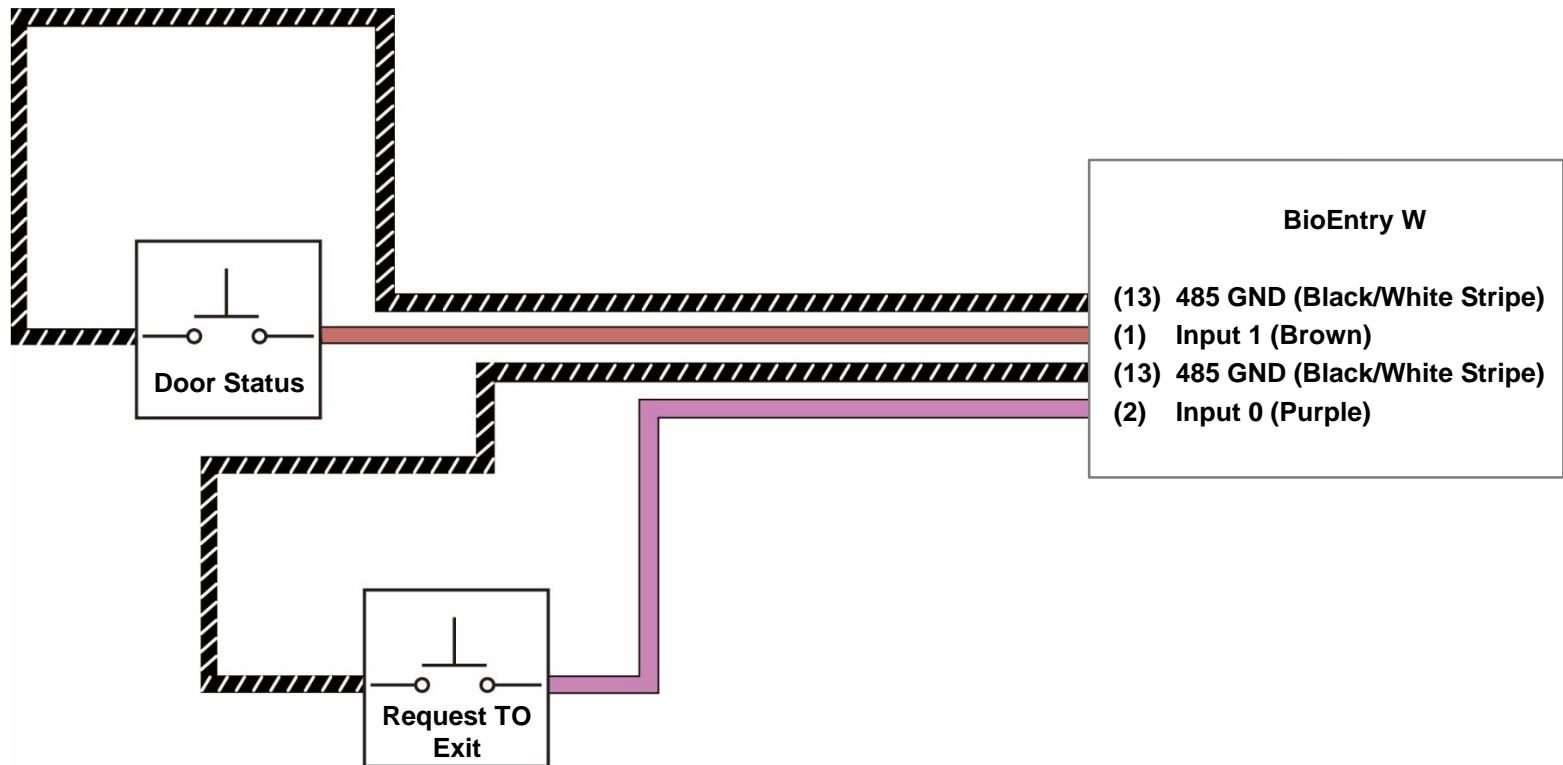

Connections

- Digital Input Connection (Alarm/ Emergency switch)

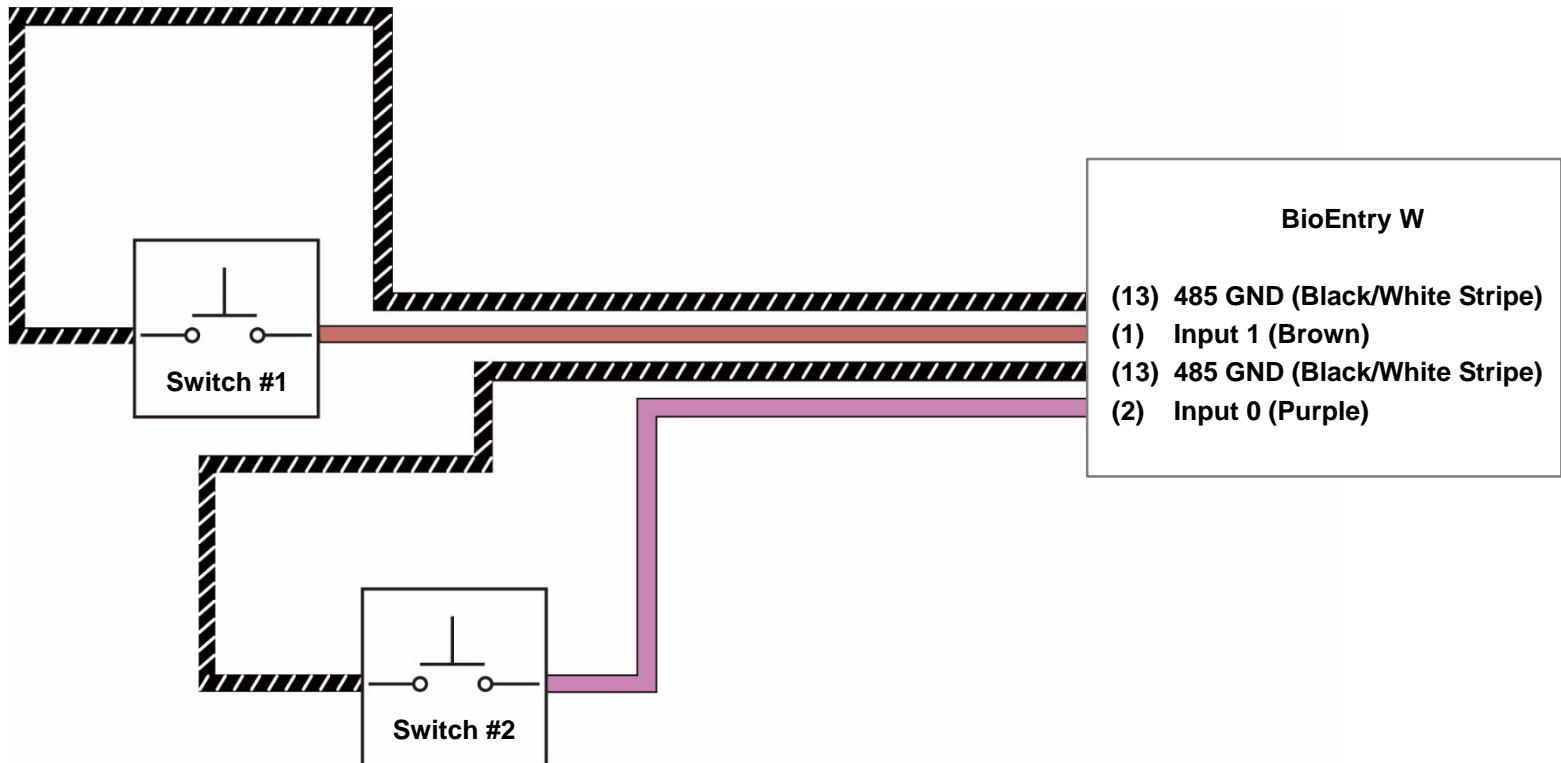

Connections

■ Wiegand Input



■ Wiegand Output



Resetting Network Settings

In case of forgetting network setting of the device (TCP/IP or RS-485 setting) during installation or using the device, you can initialize network setting (TCP/IP or RS-485 setting) by using the network reset switch on the back panel of the device. Please refer to the figures as below.

1. Turn on the device.
2. Press and hold the network reset switch until the device turns off. (Then, the device will restart.)

Network Default Setting

- TCP/IP Address : 192.168.0.1
- Not checked "Use Server"
- RS-485 : PC Connection, 115200bps

3. Modify then save the TCP/IP or RS485 settings.
4. Reboot the device.
5. Confirm the new settings.

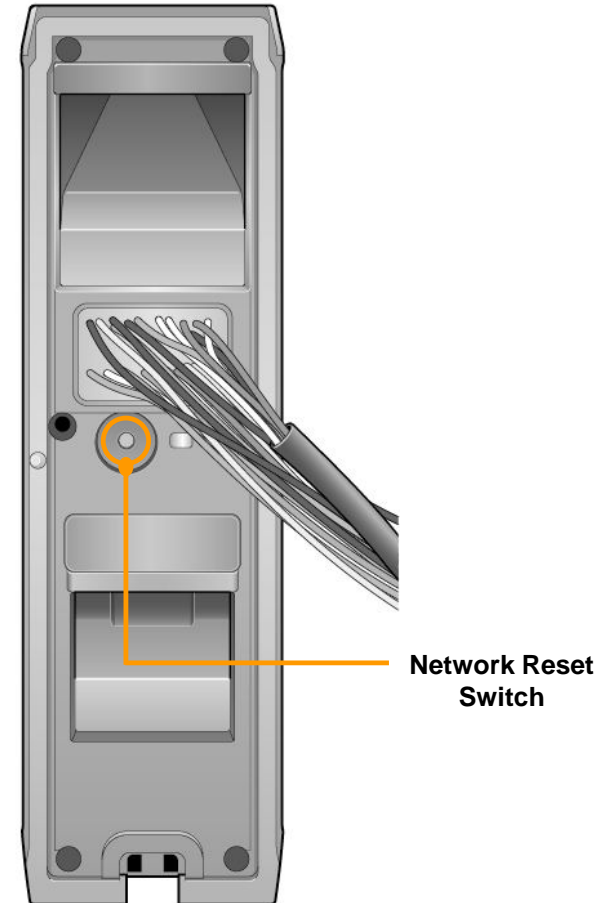

Electrical Specifications

		Min.	Typ.	Max.	Notes
Power	Voltage (V)	10.8	12	13.2	Use regulated DC power adaptor only.
	Current Consumption (mA)	-		260	
Switch Input	V _{IH} (V)	2.0	-	10.0	The input ports are pulled up with 4.7k resistors.
	V _{IL} (V)	-	-	0.4	
	Pull-up resistance (Ω)	-	4.7k	-	
TTL/ Wiegand Output	V _{OH} (V)	-	5	-	The outputs ports are open drain type, pulled up with 4.7k resistors internally.
	V _{OL} (V)	-	0.8	-	
	Pull-up resistance (Ω)	-	4.7k	-	
Relay	Voltage	-	-	24 VDC	
	Current	-	0.5 A	1.0 A	

Product Specifications

System	Max Users		5000 users (10,000 templates) [1:1 & 1:N]
	Log Capacity		50,000 logs
	CPU		533MHz DSP
	Memory		8MB Flash + 8MB RAM
	RF Options		125KHz HID Prox, 13.56MHz Mifare/DESFire 13.56MHz iCLASS SE/Felica
	Interfaces		TCP/IP, RS485, Wiegand
	Input / Output		2 TTL Inputs, 1 Relay Output
	Power		12VDC, PoE (Power over Ethernet)
General	Dimensions	BioEntry W (W x H x D)	50 x 172 x 44 mm
		Wall Bracket (W x H)	40 x 157 mm (screw joint included)

Troubleshooting

Please contact your local dealer/distributor for support or contact Suprema at support@supremainc.com. Please submit the following information and we will coordinate support with your local dealer/distributor.

- Device model
- F/W version of the device
- H/W version of the device
- Detailed information regarding the issue
- Error messages / screenshots, if possible
- Contact information (Company, Name, Telephone, Email)

Precautions for Device Cleaning

- Wipe out the device surface with dry towel or cloth.
- Use a soft dry towel when removing dust or impurities from the surface of the sensor.
- Cleaning the sensor with a detergent, benzene or thinner will damage the surface and disrupt the unit's ability to properly read a fingerprint.

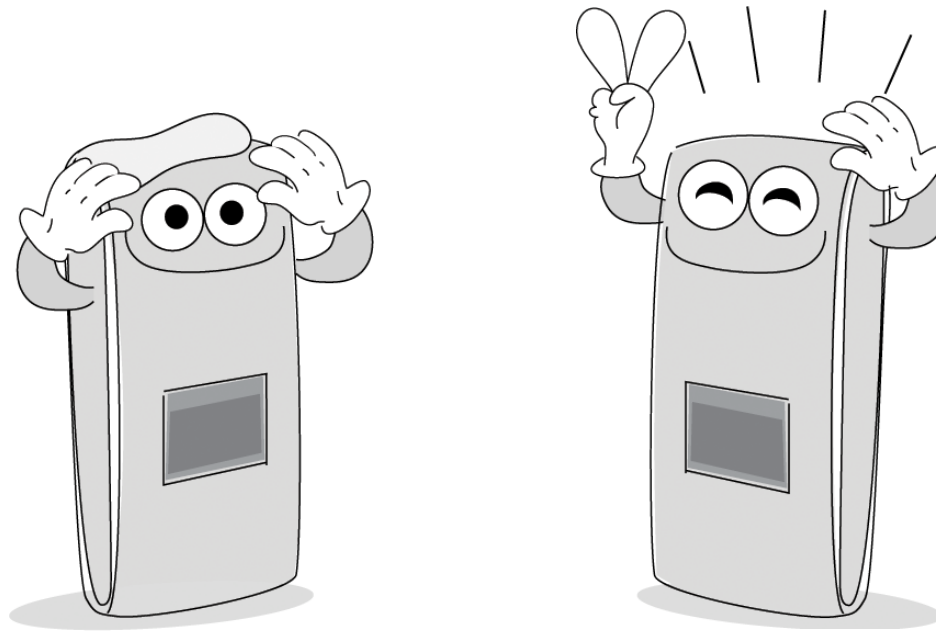

FCC Rules

- **Caution**

Changes or modifications not expressly approved by the manufacturer responsible for compliance could void the user's authority to operate the equipment.

- **Warning**

This device complies with part 15 of the FCC Rules. Operation is subject to the following two conditions: (1) This device may not cause harmful interface, and (2) this device must accept any interface received, including interference that may cause undesired operation.

- **Information to User**

This equipment has been tested and found to comply with the limit of a Class B digital device, pursuant to Part 15 of the FCC Rules. These limits are designed to provide reasonable protection against harmful interference in a residential installation. This equipment generates, user and can radiate radio frequency energy and, if not installed and used in accordance with the instructions, may cause harmful interference to radio communications. However, there is no guarantee that interference will not occur in a particular installation; if this equipment does cause harmful interference to radio or television reception, which can be determined by turning the equipment off and on, the user is encouraged to try to correct the interference by one or more the following measures:

1. Reorient / Relocate the receiving antenna.
2. Increase the separation between the equipment and receiver.
3. Connect the equipment into an outlet on a circuit difference from that to which the receiver is connected.
4. Consult the dealer or an experienced radio/TV technician for help.



Suprema Inc.

16F Parkview Tower, 6 Jeongja, Bundang, Seongnam, Gyeonggi, 463-863 Korea

Tel: +82-31-783-4502 | Fax: +82-31-783-4503

Email: sales@supremainc.com | Homepage: www.supremainc.com